

Precaution on side: Fuse max. 16 A stagnant

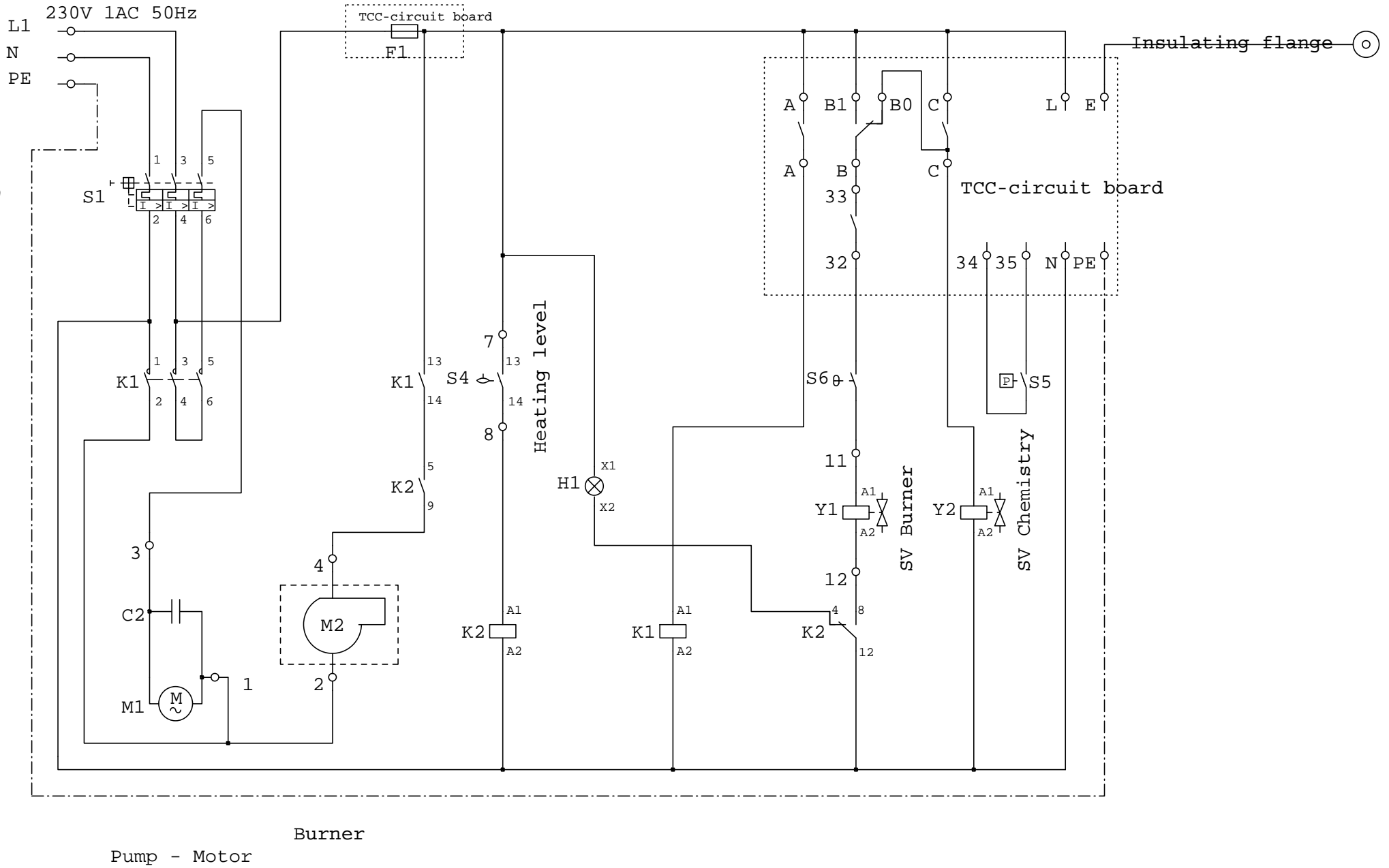

Pump - Motor
Burner

			Datum	14.12.2012
			Bearb.	
			Gepr.	
Zust.	Änderung	Datum	Name	Norm



FH 711 TCC
HW 706 TCC

Zeichnungsnr.:	2-09.78.16.000-0	=	
		+	
			Blatt 1
			von 1Bl.